

| ROAD CLASSIFICATION INFORMATION | |
|---|------|
| DESIGN SPEED (MPH) | - |
| ADT RANGE | N/A |
| GENERAL LENGTH | 400' |
| MIN. TANGENT LENGTH BETWEEN HORIZONTAL CURVES | N/A |
| MINIMUM CURB BASIS | - |

| IMPERVIOUS COVER INFORMATION (FOR WATER QUALITY/DETENTION POND SIZING) | |
|--|-----------|
| IMPERVIOUS COVER (PERCENT OF ROW) | 80% |
| IMPERVIOUS COVER (SF PER 1,000 LF OF ROADWAY) | 20,000 SF |



CITY OF BEE CAVE
ROAD CROSS SECTIONS

EXHIBIT A

ROAD CLASSIFICATION:
ALLEY SECTION

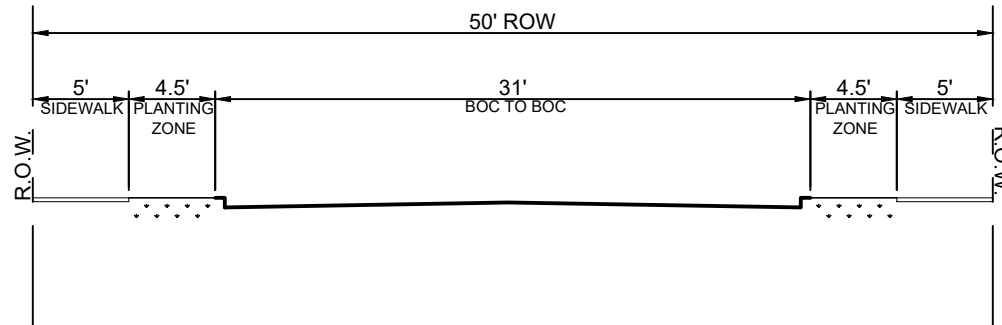

| ROAD CLASSIFICATION INFORMATION | |
|---|--------|
| DESIGN SPEED (MPH) | 25, 30 |
| ADT RANGE | <1,000 |
| MIN. TANGENT LENGTH BETWEEN HORIZONTAL CURVES | 50' |
| MINIMUM CURB BASIS | 10' |

| IMPERVIOUS COVER INFORMATION (FOR WATER QUALITY/DETENTION POND SIZING) | |
|--|-----------|
| IMPERVIOUS COVER (PERCENT OF ROW) | 82% |
| IMPERVIOUS COVER (SF PER 1,000 LF OF ROADWAY) | 40,100 SF |



CITY OF BEE CAVE
ROAD CROSS SECTIONS

EXHIBIT B

ROAD CLASSIFICATION:
LOCAL RESIDENTIAL

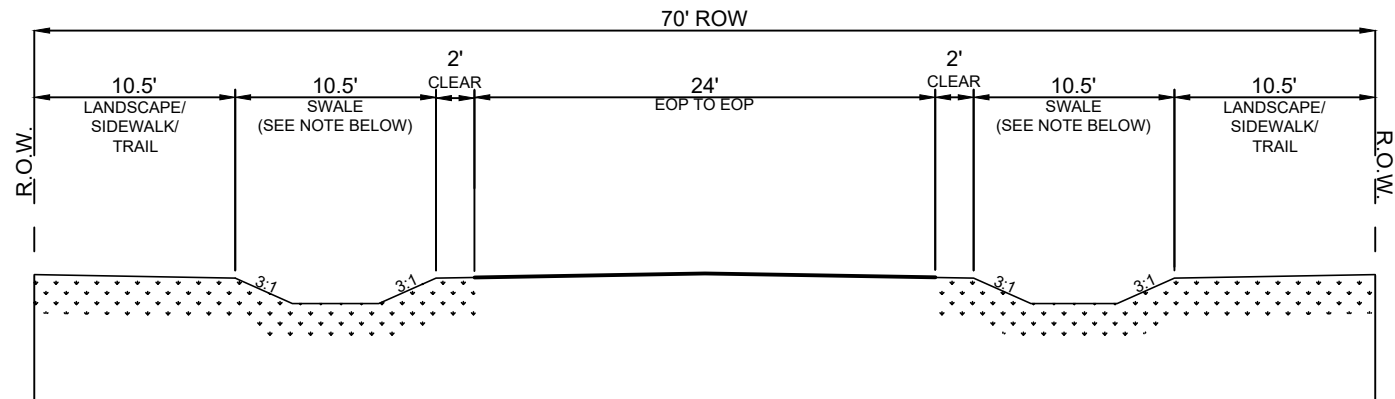

NOTE: THE CITY ENGINEER MAY APPROVE A REDUCED ROADSIDE SWALE WIDTH IF IT CAN BE DEMONSTRATED THAT THE REDUCED WIDTH WILL FULLY CONVEY DESIGN STORM EVENTS (IN ACCORDANCE WITH COA DCM)

| ROAD CLASSIFICATION INFORMATION | |
|---|--------|
| DESIGN SPEED (MPH) | 25 |
| ADT RANGE | <1,000 |
| MIN. TANGENT LENGTH BETWEEN HORIZONTAL CURVES | 50' |
| MINIMUM CURB BASIS | N/A |

| IMPERVIOUS COVER INFORMATION (FOR WATER QUALITY/DETENTION POND SIZING) | |
|--|-----------|
| IMPERVIOUS COVER (PERCENT OF ROW) | 63% |
| IMPERVIOUS COVER (SF PER 1,000 LF OF ROADWAY) | 40,400 SF |



CITY OF BEE CAVE
ROAD CROSS SECTIONS

EXHIBIT C

ROAD CLASSIFICATION:
RURAL RESIDENTIAL

OPTION WITH PARKING

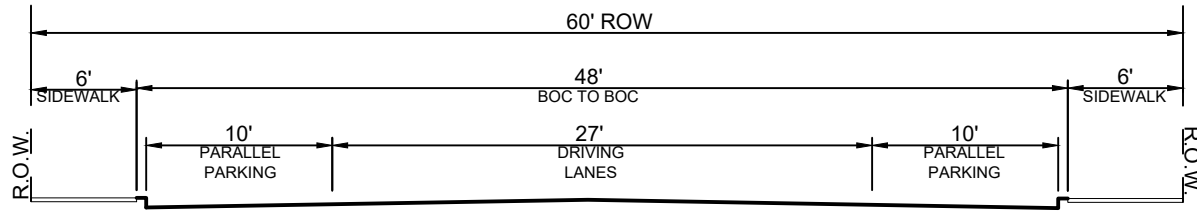

NOTE: AT A MINIMUM, EVERY 5 PARALLEL PARKING SPACES SHALL BE FOLLOWED BY A EQUIVALENTLY SIZED PLANTING ZONE.

OPTION WITHOUT PARKING

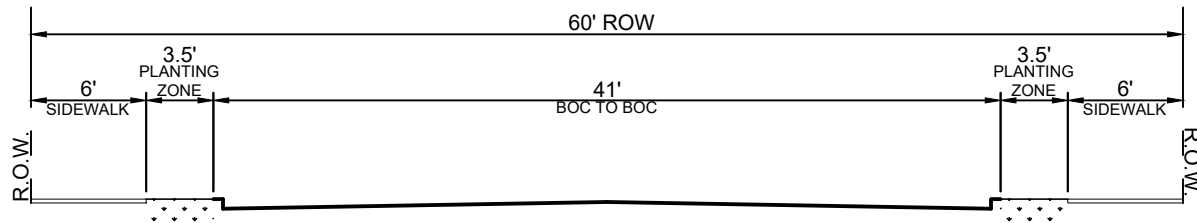

| ROAD CLASSIFICATION INFORMATION | |
|---|-------------|
| DESIGN SPEED (MPH) | 30, 35 |
| ADT RANGE | 500 - 3,000 |
| MIN. TANGENT LENGTH BETWEEN HORIZONTAL CURVES | 50' |
| MINIMUM CURB BASIS | 10' |

| IMPERVIOUS COVER INFORMATION (FOR WATER QUALITY/DETENTION POND SIZING) | | |
|--|-----------|--|
| IMPERVIOUS COVER (PERCENT OF ROW) | 88% | FOR PARALLEL PARKING - VARIES BASED ON ROADWAY LENGTH/NUMBER OF PARALLEL SPOTS |
| IMPERVIOUS COVER (SF PER 1,000 LF OF ROADWAY) | 53,000 SF | |



CITY OF BEE CAVE
ROAD CROSS SECTIONS

EXHIBIT D

ROAD CLASSIFICATION:
RESIDENTIAL COLLECTOR

OPTION WITH PARKING

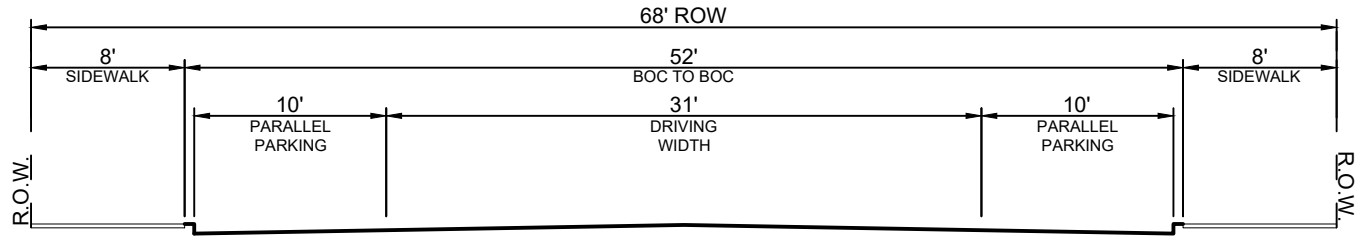

NOTE: AT A MINIMUM, EVERY 5 PARALLEL PARKING SPACES SHALL BE FOLLOWED BY AN EQUIVALENTLY SIZED PLANTING ZONE.

OPTION WITHOUT PARKING

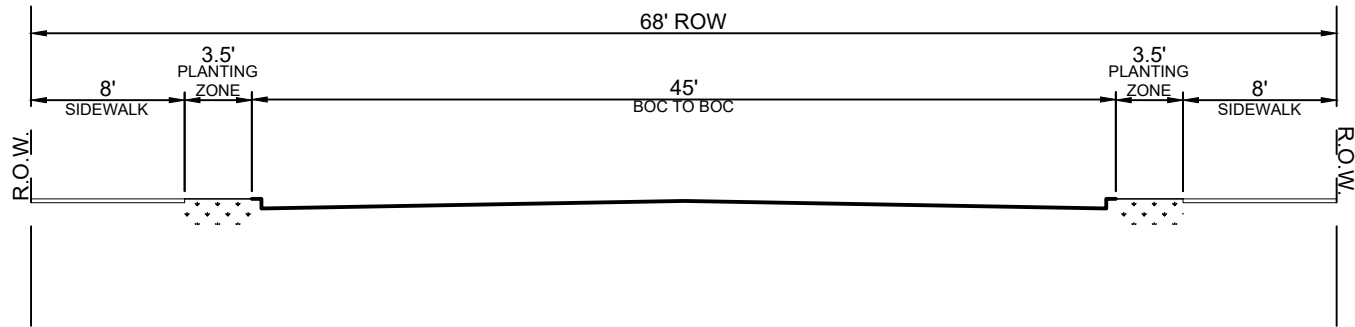

| ROAD CLASSIFICATION INFORMATION | |
|---|---------------|
| DESIGN SPEED (MPH) | 35 |
| ADT RANGE | 2,000 - 6,000 |
| MIN. TANGENT LENGTH BETWEEN HORIZONTAL CURVES | 100' |
| MINIMUM CURB BASIS | 12' |

| IMPERVIOUS COVER INFORMATION (FOR WATER QUALITY/DETENTION POND SIZING) | | |
|--|-----------|--|
| IMPERVIOUS COVER (PERCENT OF ROW) | 90% | FOR PARALLEL PARKING - VARIES BASED ON ROADWAY LENGTH/NUMBER OF PARALLEL SPOTS |
| IMPERVIOUS COVER (SF PER 1,000 LF OF ROADWAY) | 61,000 SF | |



CITY OF BEE CAVE
ROAD CROSS SECTIONS

EXHIBIT E

ROAD CLASSIFICATION:
NEIGHBORHOOD COLLECTOR

OPTION WITH PARKING

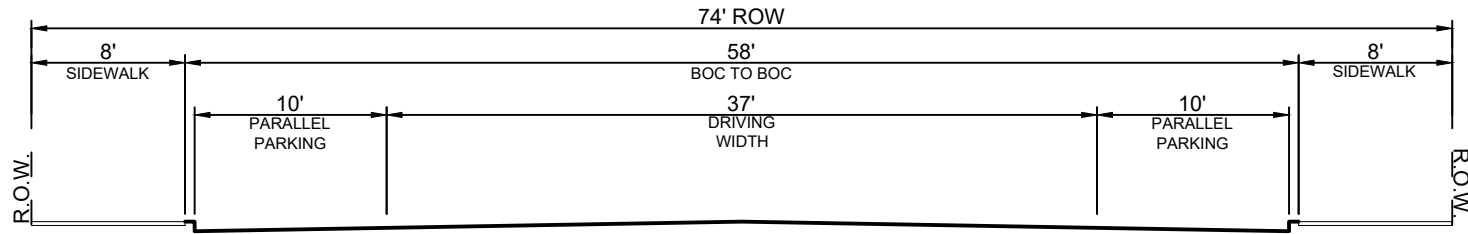

NOTE: AT A MINIMUM, EVERY 5 PARALLEL PARKING SPACES SHALL BE FOLLOWED BY A EQUIVALENTLY SIZED PLANTING ZONE.

OPTION WITHOUT PARKING

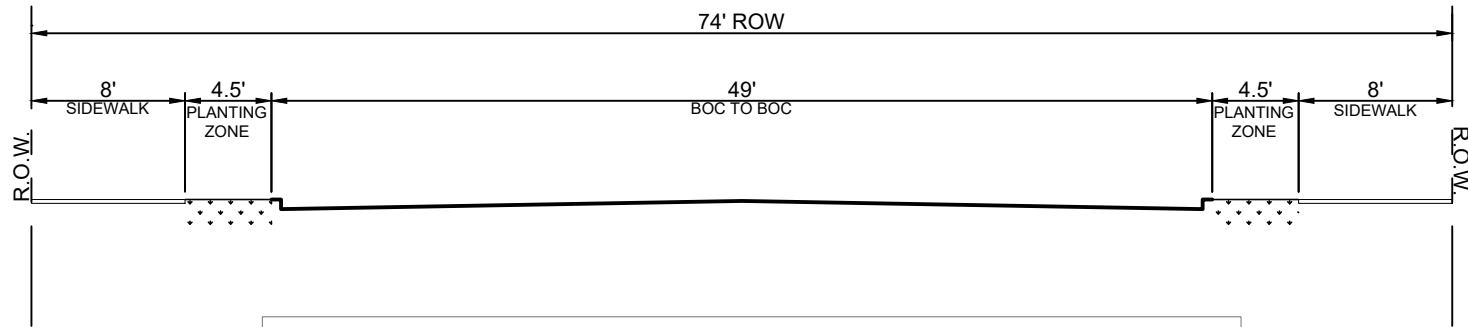

| ROAD CLASSIFICATION INFORMATION | |
|---|---------|
| DESIGN SPEED (MPH) | 35 |
| ADT RANGE | <10,000 |
| MIN. TANGENT LENGTH BETWEEN HORIZONTAL CURVES | 100' |
| MINIMUM CURB BASIS | 13' |

| IMPERVIOUS COVER INFORMATION (FOR WATER QUALITY/DETENTION POND SIZING) | | |
|--|-----------|--|
| IMPERVIOUS COVER (PERCENT OF ROW) | 88% | FOR PARALLEL PARKING - VARIES BASED ON ROADWAY LENGTH/NUMBER OF PARALLEL SPOTS |
| IMPERVIOUS COVER (SF PER 1,000 LF OF ROADWAY) | 65,000 SF | |



CITY OF BEE CAVE
ROAD CROSS SECTIONS

EXHIBIT F

ROAD CLASSIFICATION:
PRIMARY COLLECTOR
(UNDIVIDED)

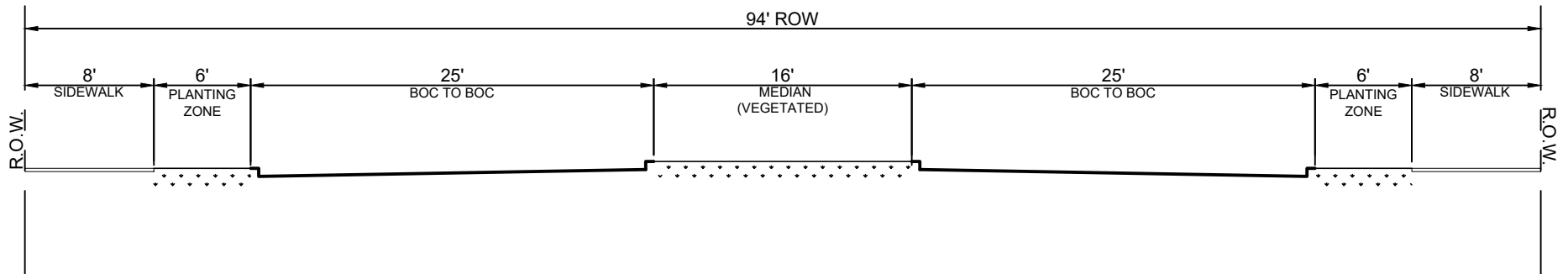

| ROAD CLASSIFICATION INFORMATION | |
|---|---------|
| DESIGN SPEED (MPH) | 35 |
| ADT RANGE | <10,000 |
| MIN. TANGENT LENGTH BETWEEN HORIZONTAL CURVES | 100' |
| MINIMUM CURB BASIS | 14.5' |

| IMPERVIOUS COVER INFORMATION (FOR WATER QUALITY/DETENTION POND SIZING) | |
|--|-----------|
| IMPERVIOUS COVER (PERCENT OF ROW) | 70% |
| IMPERVIOUS COVER (SF PER 1,000 LF OF ROADWAY) | 66,000 SF |



CITY OF BEE CAVE
ROAD CROSS SECTIONS

EXHIBIT G

ROAD CLASSIFICATION:
PRIMARY COLLECTOR
(DIVIDED)

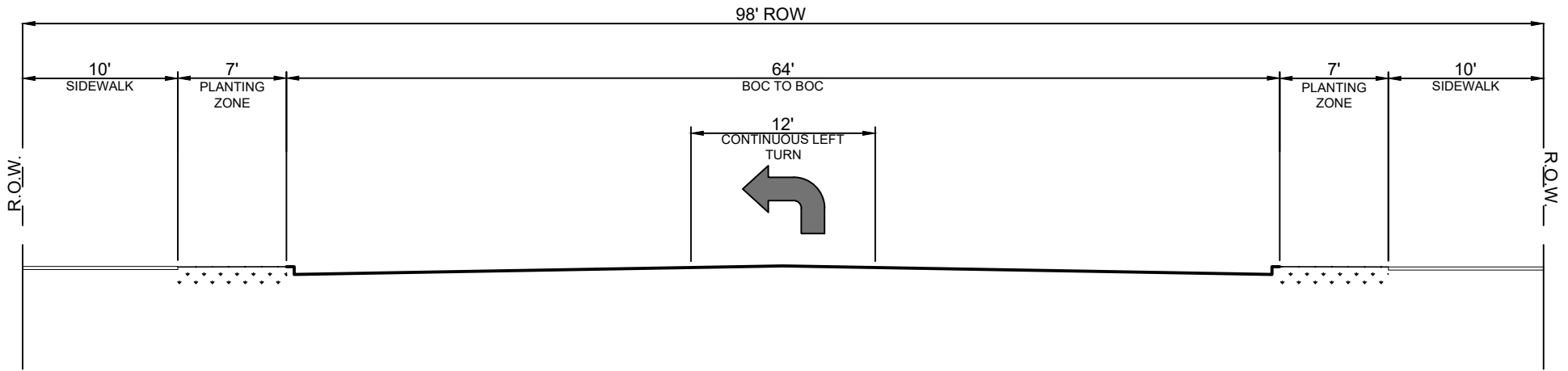

| ROAD CLASSIFICATION INFORMATION | |
|---|----------------|
| DESIGN SPEED (MPH) | 45 |
| ADT RANGE | 5,000 - 15,000 |
| MIN. TANGENT LENGTH BETWEEN HORIZONTAL CURVES | 150' |
| MINIMUM CURB BASIS | 17.5' |

| IMPERVIOUS COVER INFORMATION (FOR WATER QUALITY/DETENTION POND SIZING) | |
|--|-----------|
| IMPERVIOUS COVER (PERCENT OF ROW) | 86% |
| IMPERVIOUS COVER (SF PER 1,000 LF OF ROADWAY) | 84,000 SF |



CITY OF BEE CAVE
ROAD CROSS SECTIONS

EXHIBIT H

ROAD CLASSIFICATION:
MINOR ARTERIAL WITH CONT. LEFT TURN LANE

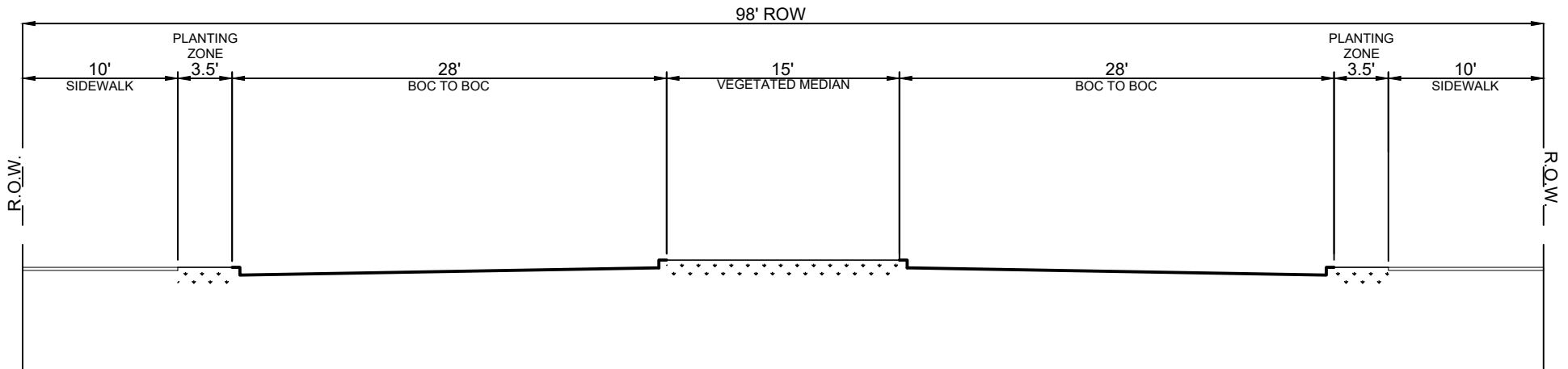

| ROAD CLASSIFICATION INFORMATION | |
|---|----------------|
| DESIGN SPEED (MPH) | 45 |
| ADT RANGE | 9,000 - 20,000 |
| MIN. TANGENT LENGTH BETWEEN HORIZONTAL CURVES | 150' |
| MINIMUM CURB BASIS | 14' |



CITY OF BEE CAVE
ROAD CROSS SECTIONS

EXHIBIT I

ROAD CLASSIFICATION:
MINOR ARTERIAL (4 LANE DIVIDED)

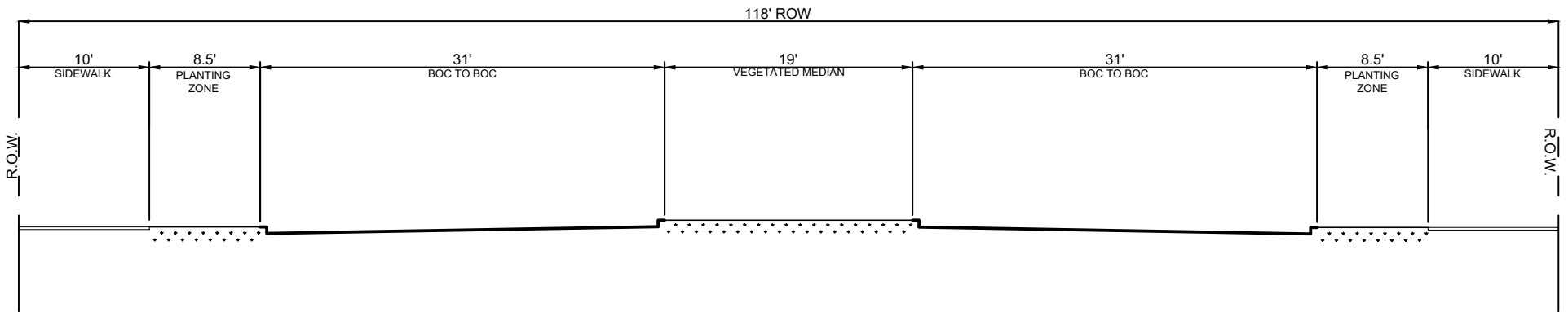

| ROAD CLASSIFICATION INFORMATION | |
|---|----------------|
| DESIGN SPEED (MPH) | 45 |
| ADT RANGE | 9,000 - 35,500 |
| MIN. TANGENT LENGTH BETWEEN HORIZONTAL CURVES | 150' |
| MINIMUM CURB BASIS | 19' |



CITY OF BEE CAVE
ROAD CROSS SECTIONS

EXHIBIT J

ROAD CLASSIFICATION:
MAJOR ARTERIAL (4 LANE DIVIDED)